



F900 SERIES

User, installation and servicing instructions

FRYER

G9341, G9341F

Read these instructions before use

DATE PURCHASED:

MODEL NUMBER:

SERIAL NUMBER:

DEALER:

SERVICE PROVIDER:

DRAFT REV 6

T100889

Published: 5/10/15

Dear Customer,
Thank you for choosing Falcon Foodservice Equipment.

This manual can be downloaded from www.falconfoodservice.com or scan here



IMPORTANT: Please keep this manual for future reference.

Falcon Foodservice Equipment

HEAD OFFICE

Wallace View, Hillfoots Road, Stirling. FK9 5PY. Scotland.

WEEE Directive Registration No. WEEE/DC0059TT/PRO



At end of appliance life, dispose of appliance and any replacement parts in a safe manner, via a licensed waste handler. Appliances are designed to be dismantled easily and recycling of all material is encouraged whenever practicable.



SYMBOLS•



• SPANNER



• SCREWDRIVER



• COOKING OIL



• GREASE

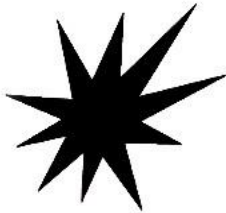

• SPARK IGNITION



• FLAME



• WARNING



• VIEWPORT



• ALLEN KEY



•IGNITER



These instructions are only valid if the country code appears on the appliance. If the code does not appear on the appliance, refer to the technical instructions for adapting the appliance to the conditions for use in that country.

Installation must meet national or local regulations. Attention must be paid to: gas safety (installation & use) regulations, health and safety at work act, local and national building regulations, fire precautions act.

To prevent shocks, all appliances Must Be Earth Bonded.

The unit is fitted with Equipotential connection at the rear on the base .

This equipment is for professional use only and must be used by qualified persons.

The installer must instruct the responsible person(s) of the correct operation and maintenance of the appliance.

Only competent persons are allowed to service or convert the appliance to another gas type.

Gas appliances must have a stop cock fitted in the supply pipe work. The user must be familiar with the location and operation of this device in order to turn off the supply of gas in the event of an emergency.

Unless otherwise stated, parts which have been protected by the manufacturer must not be adjusted by the installer.

Take care when moving an appliance fitted with castors.

The appliance must be serviced regularly by a qualified person. Service intervals should be agreed with the service provider.



This appliance may be discoloured due to intensive testing. This does not affect its quality or performance.

CONTENTS

1	APPLIANCE INFORMATION.....	6
2	OPERATION.....	7
2.1	COMPONENT PARTS.....	7
2.2	CONTROLS G9341/F.....	8
2.3	USING THE APPLIANCES.....	9
3	CLEANING AND MAINTENANCE.....	11
4	SPECIFICATION.....	12
4.1	TABLE A.....	12
4.2	TABLE B – G20.....	13
4.3	TABLE B – G30/G31.....	13
5	DIMENSIONS / CONNECTION LOCATIONS.....	14
6	INSTALLATION.....	15
6.1	SITING / CLEARANCES.....	15
6.2	VENTILATION.....	16
6.3	GAS /ELECTRIC SUPPLY & CONNECTION.....	16
6.4	ASSEMBLY.....	17
6.5	COMMISSIONING.....	18
7	CONVERSION.....	19
7.1	GAS CONVERSION CHECK LIST.....	19
8	SERVICING.....	21
8.1	DOOR.....	21
8.2	CONTROL PANEL.....	22
8.3	FASTRON CONTROLLER & NEONS.....	22
8.4	SWITCH PANEL.....	22
8.5	SWITCH & NEON REMOVAL.....	23
8.6	ACCESS TO SPARK BOX.....	24
8.7	SIT GAS REGULATOR ACCESS.....	25
8.8	PUMP & TIMER REMOVAL.....	25
8.9	26	
8.10	Timer Pump Settings for 230 volts.....	26
9	ACCESSORIES.....	27
9.1	Splash guard.....	27
9.2	Drain hose.....	27
10	FAULT FINDING.....	28
11	SPARE PARTS.....	29
12	SERVICE INFORMATION.....	29

1 APPLIANCE INFORMATION

This appliance has been CE-marked on the basis of compliance with the relevant EU directives for the heat inputs, gas pressures and voltages stated on the data plate.

Falcon Foodservice Equipment  P.I.N. STD. 

A Ser No. **B** MODEL **C** TYPE I.P.

	AT, CH, CY, CZ, DK, EE, FI, GR, IT, LT, NO, RO, SE, SI, SK	BE, CH, CY, CZ, ES, FR, GB, GR, IE, IT, LT, PT, SI, SK	DE, PL, RO	AT, BE, CH, CY, CZ, DE, DK, EE, FR, GB, GR, HU, IT, LT, NL, PL, RO, SE, SI, SK	CH, CY, CZ, ES, GB, GR, IE, IT, LT, PT, SI, SK	DE, PL, RO	AT, CH, CY, CZ, DK, EE, ES, FI, FR, GB, GR, IE, IT, LT, LU, LV, NL, NO, PT, RO, SE, SI, SK	BE, CY, ES, FI, FR, GB, GR, IE, PT	BE, CH, CZ, ES, FR, GB, GR, IE, IT, LT, NL, PL, PT, SI, SK
D Cat.	I12H3B/P	I3+	I12E3B/P	I3B/P	I12H3+	I2E	I2H	I3B	I3P
E p mbar	20;30;50	28-30/37	20;30;50	30;50	20;28-30/37	20	20	28-30	37
F GAS TYPE	G20		G30	G31					
G GAS RATE	m3/h		kg/h	kg/h					
H Σ Qn	KW		KW	kW					
I EL.	<input type="text"/>								Hz
J Σ kW	<input type="text"/>		kW	<input type="text"/>		K <input type="text"/>		kHz	
L	L1	A	L2	A	L3	A			

A - Serial No

B - Model No

C - Flue Type

D - Gas Category

E - Gas Pressure

F - Gas Type

G - Gas Rate

H - Total Heat Input

I - Electrical Rating

J - Total Electrical Power

K - Magnetic Field Frequency

L - Electrical Phase Loading

2 OPERATION

2.1 COMPONENT PARTS

FRYER

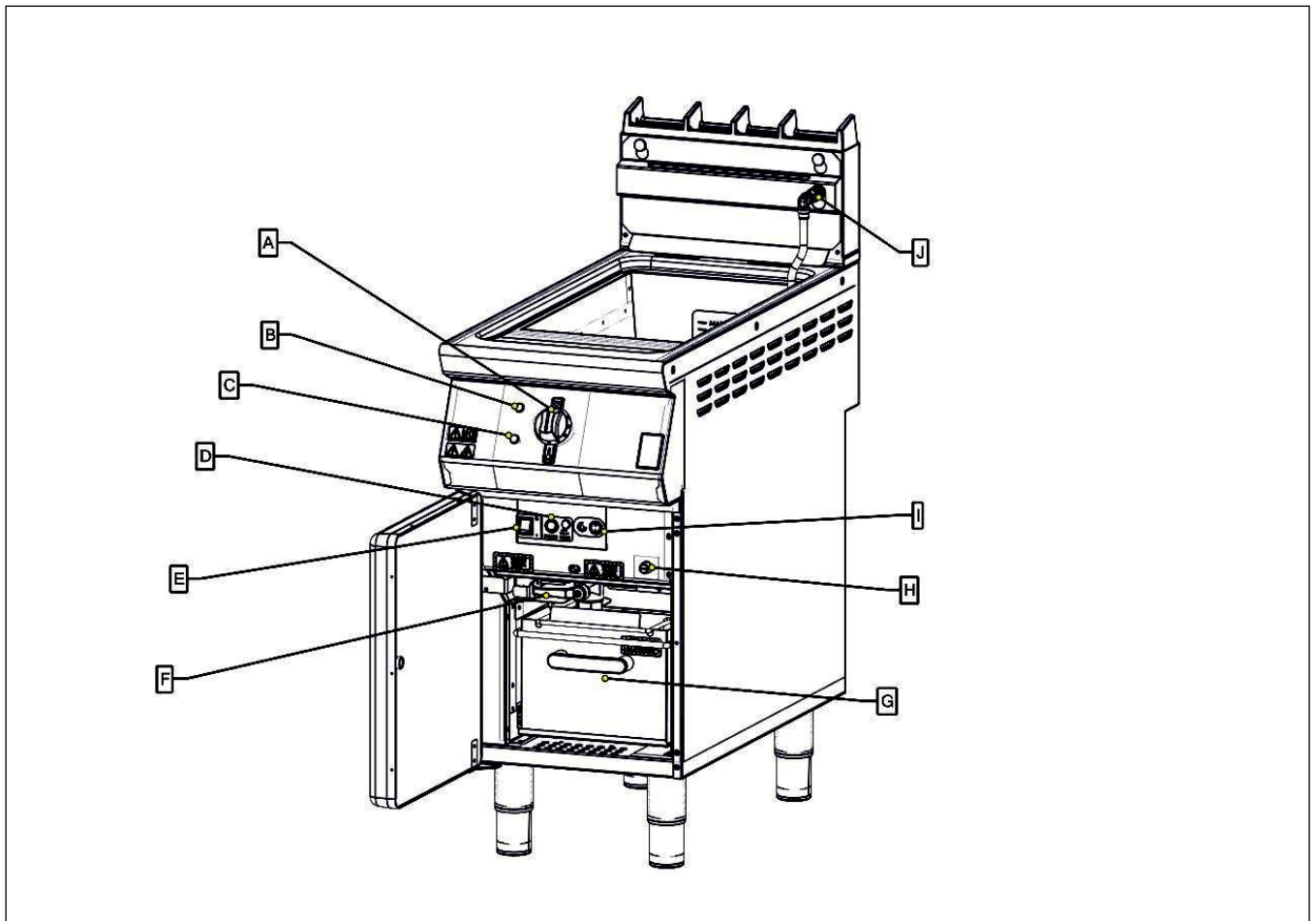

A – TEMPERATURE CONTROL

B – POWER NEON (RED)

C – HEAT DEMAND NEON (AMBER)

D – BURNER RESET

E – Power ON/OFF RESET

F – DRAIN VALVE

G – OIL BUCKET

H – SAFETY LIMITER

I – PUMP SWITCH

J – QUICK RELEASE RETURN PIPE

2.2 CONTROLS G9341/F

2.2.1 **ON/OFF Temperature control knob**

Temperature Selection (140 -190°C) (Unit off when control is in position Indicated).

2.2.2 **Fat Melting Position**

2.2.3 **Power on Indicator**

2.2.4 **Heat Demand Indicator**

Illuminates when the thermostat demands heat, i.e. oil temperature is more than

5° C below temperature setting.

Extinguishes when desired temperature is reached.

2.2.5 **Burner and Temperature Controls on/off Switch**

Cuts power and temperature controls

2.2.6 **Burner Lock-out Switch**

(Reset burner for further lighting attempts when burner lockout indicator is Illuminated).

2.2.7 **Burner lock-out Indicator** (Indicates flame failure).

2.2.8 **Filtration Pump Switch (G9341F only)**

Energizes filtration pump when burner is in OFF (O) position.

2.2.9 **Temperature Safety Limiter Reset Button**

Located inside red recess below black cover.

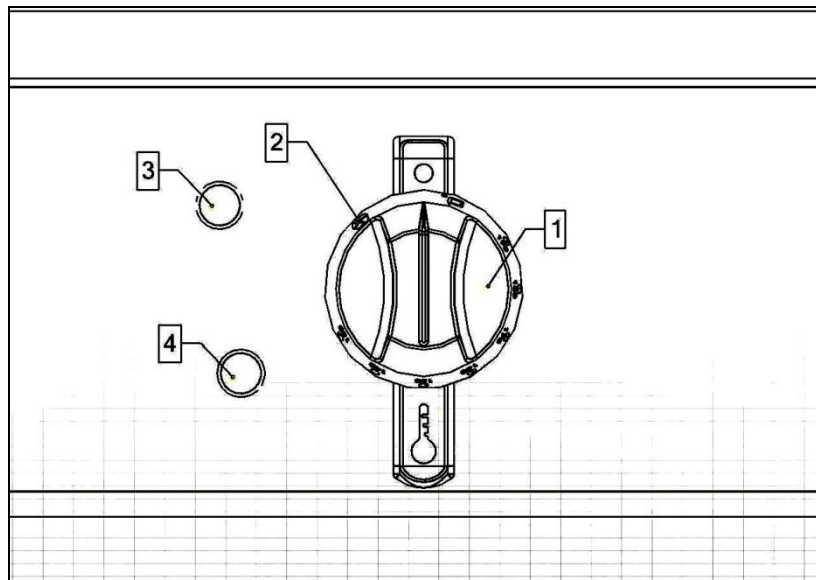

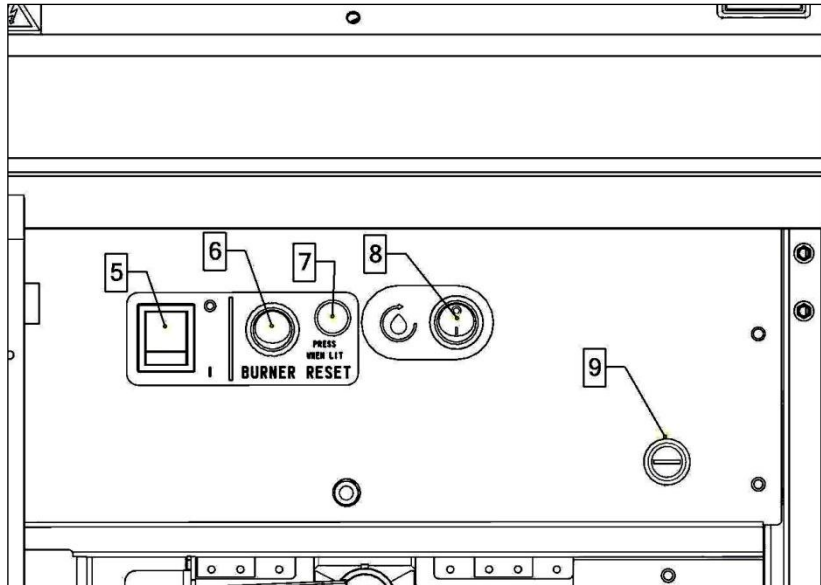

2.3 USING THE APPLIANCES

2.3.1 Always clean the appliance before use. See section 3.0

2.3.2 Ensure drain valve is closed. Fill pan with cooking medium to -MIN- (*maximum cold fill mark*). Do not fill medium past MAX level mark.



MIN- Level Mark: Medium should NEVER be allowed to drop below this mark. Should this occur, top up immediately or switch fryer OFF.

CAUTION: SUITABLE PROTECTIVE CLOTHING

MUST BE WORN when topping up whilst fat in fryer is hot.

Medium and Foodstuffs

Food will increase in volume during cooking - follow these rules:

NEVER ADD WATER TO FRYING MEDIUM AT ANY TIME!

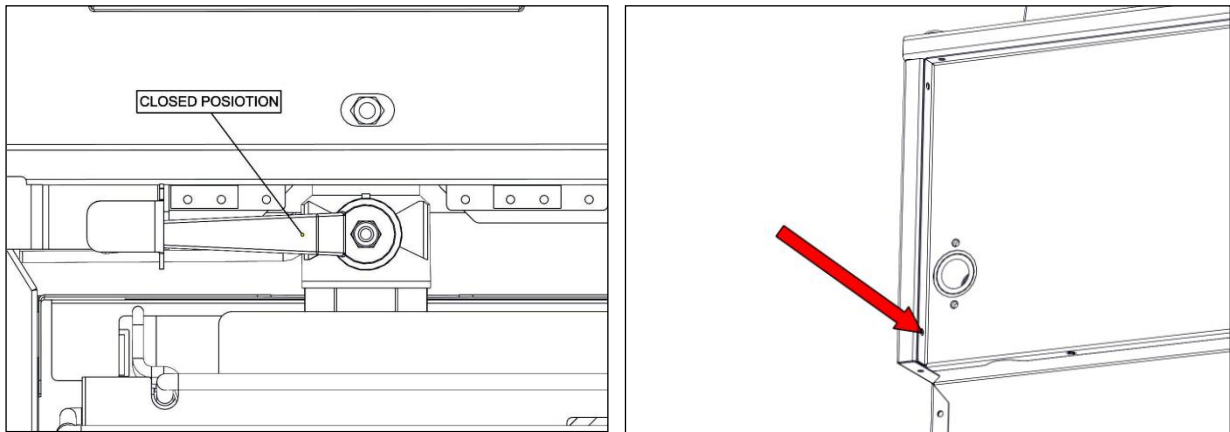

2.3.3 Switch power on 2.2.5

2.3.4 Set temperature 2.2.1. If solid fat is to be used, Ensure FAT MELT CYCLE is selected for this process 2.2.2

Medium should not be overheated as this will increase the risk of fire.

Note: NEVER leave a working unit unattended.

Note: Fryer is fitted with a thermal safety device. This will stop heating of medium if it becomes overheated. This appliance will always fail safe.



2.3.5 Fryer maximum basket loading.

Pre-blanch chilled fries – **2 x 1.5kg baskets.**

Frozen fries – **2 x 1.2kg baskets**

2.3.6 Turn burner off. Set temperature control 2.2.1 as above and set 2.2.5 to Off.

2.3.7 Filtration Instructions.

After filtering wait 30 seconds before removing bucket.

Switch burner off by means of burner ON/OFF Switch

Wait 15/20 mins to allow oil to cool

Lift safety drain cover

Open drain valve

Allow oil to drain from pan

Switch to filter pump

Cycle oil until pan is clear of debris

Close drain valve and allow pan to fill

Continue as indicated in lighting instructions

3 CLEANING AND MAINTENANCE

3.1.1 Turn off and cool down.

3.1.2 All surfaces are easier to clean if spillage is removed before it becomes burnt on, cleaned daily.



THE APPLIANCE MUST NOT BE STEAM CLEANED. DO NOT USE ACID OR HALOGEN-BASED (e.g. chlorine) DESCALING LIQUIDS, FLAMMABLE LIQUIDS, CLEANING AIDS OR CLEANING POWDERS.

less Steel Surfaces

It should be noted that certain scouring pads including nylon types can easily mark stainless steel. Care should be exercised during cleaning process.

When rubbing stainless steel with a cloth, always rub in grain direction.

3.1.3 The flue capper can be removed for cleaning but must be replaced for use

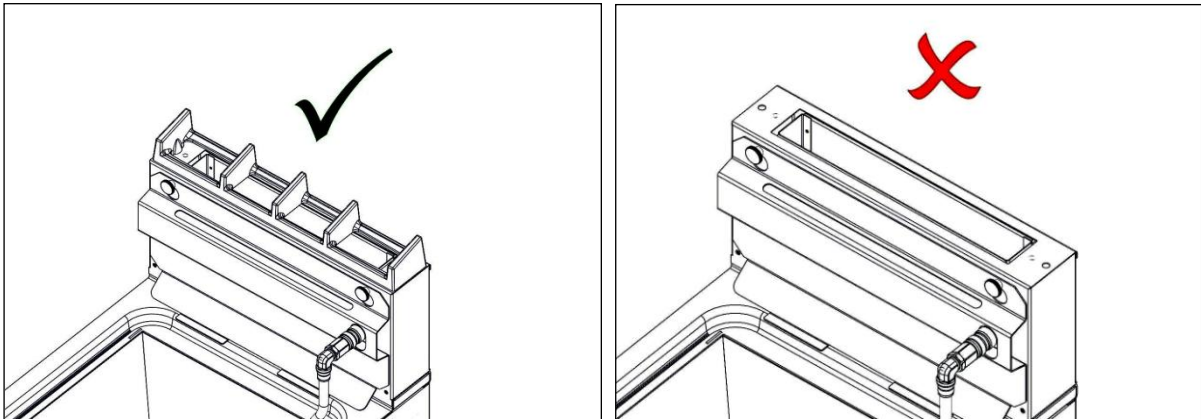

FAILURE DUE TO LACK OF PROPER CLEANING IS NOT COVERED BY WARRANTY

4 SPECIFICATION

4.1 TABLE A

TABLE A					
		G20	G31	G30	
G9341/F Fryer					
Injector		Ø2.7	Ø1.7		
Pilot Injectors		Polidora G31.2	Polidora G25		
Low Rate Screw		N/A			
Supply Pressure	mbar	20	37	29	50
	Inches w.g	8.3	14.9	11.6	20.
Operating Pressure	mbar	14	34.5	29	
	Inches w.g	5.6	13.9	11.6	
Low rate Pressure	mbar	N/A	N/A	N/A	
	Inches w.g	N/A	N/A	N/A	

TABLE A -1		
	Rated Voltage	Rated Current
G9341/F	230V	3.55 amps

4.2 TABLE B – G20

		G9341/F
Total Input	kW _{net}	23
	Btu/hr _{gross}	86,348
	m ³ /H _{net}	2.26
Test Limits	Max kW	24.15
	Min kW	21.85
	Max Btu/hr	90,666
	Min Btu/hr	82,031
	m ³ /H _{net}	

4.3 TABLE B – G30/G31

		G9341/F
Total Input	kW _{net}	22
	Btu/hr _{gross}	82,594
	kg/h G30 _{net}	1.599
	kg/h G31 _{net}	1.573
Test Limits	Max kW	23.1
	Min kW	20.9
	Max Btu/hr	86,724
	Min Btu/hr	78,464

5 DIMENSIONS / CONNECTION LOCATIONS

G9341/F UNIT WEIGHT 94 Kg

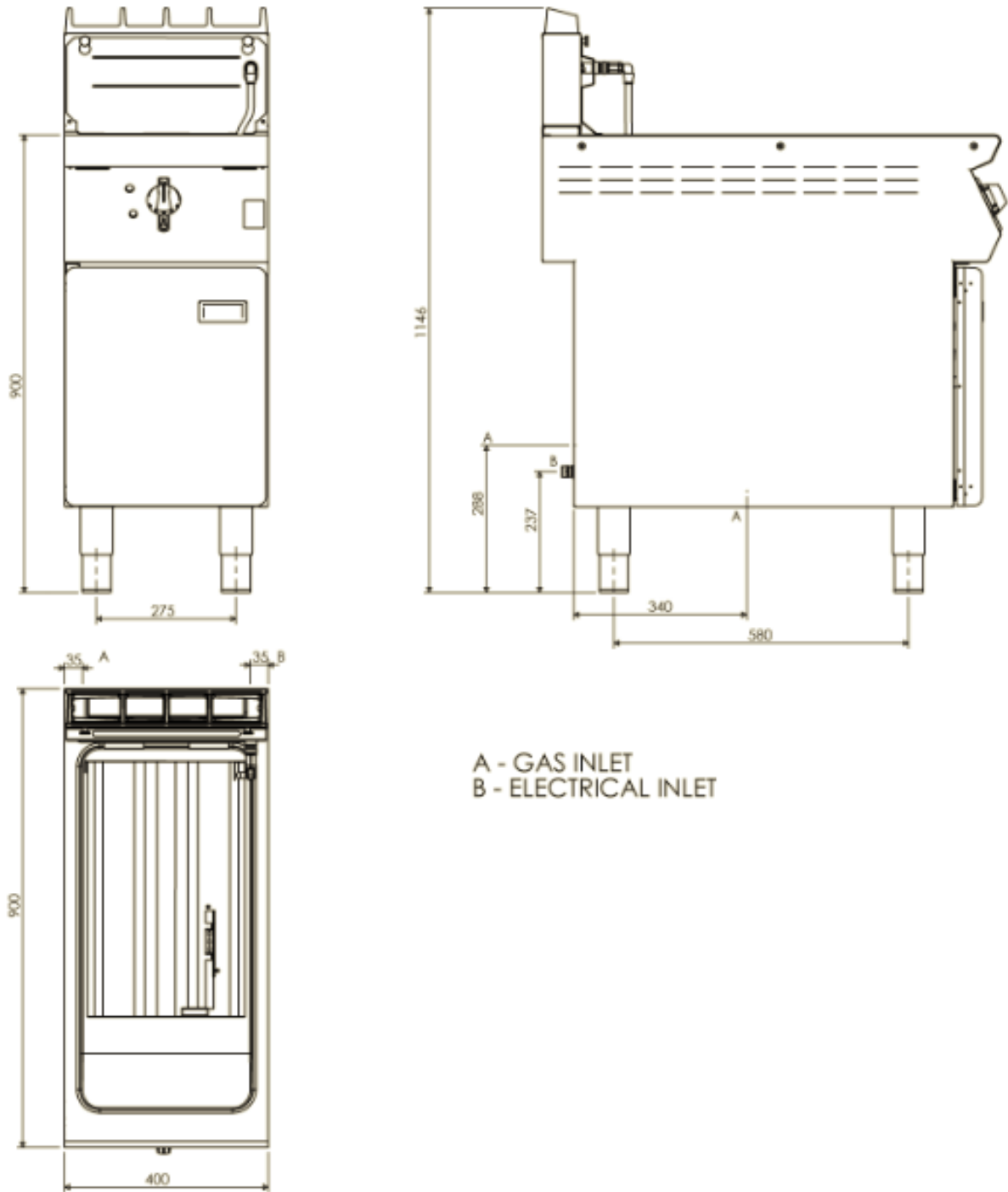

6 INSTALLATION

6.1 SITING / CLEARANCES

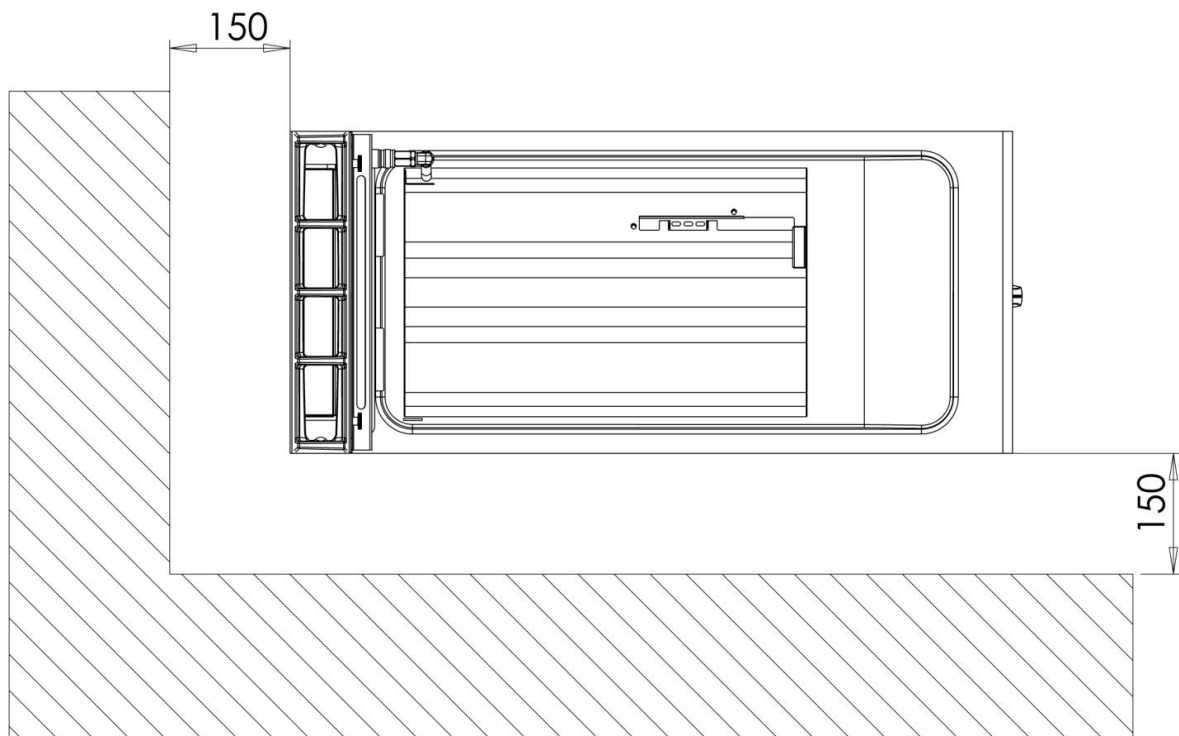

CAUTION: WALLS CLOSER THAN 150mm TO THE APPLIANCE MUST BE NON COMBUSTABLE. IF SUITING THE NECESSARY CLEARANCES TO ANY CUMBUSTIBLE WALL MUST BE THE LARGEST FIGURE GIVEN FOR INDIVIDUAL APPLIANCES INSTRUCTIONS.

6.2 VENTILATION

The appliances must to be installed with sufficient ventilation to prevent the occurrence of unacceptable concentrations of substances harmful to health in the room in which they are installed. Installer must consult any additional local / national regulations.

COMBUSTION AIR REQUIREMENTS										
	G9341	G9341F								
G20	21m ³ h	21m ³ h								
G30	20m ³ h	20m ³ h								
G31	19m ³ h	19m ³ h								

6.3 GAS /ELECTRIC SUPPLY & CONNECTION

6.3.1 A qualified installer should be called to install the appliance and if necessary to convert it for other gases.

Installation pipe work should be fitted in accordance with local / national standards. The pipe work must not be smaller than unit gas inlet connection, i.e. Rp³/₄ (3/4" B.S.P.). If using flexible hosing, the length must not exceed 1.5m. An isolating valve must be located close by for shut-down during an emergency or servicing.

If flexible hose is used, it shall comply with national requirements. These must be periodically examined and replaced as necessary. If a retention chain is required then attach the fixing on the rear top panel.

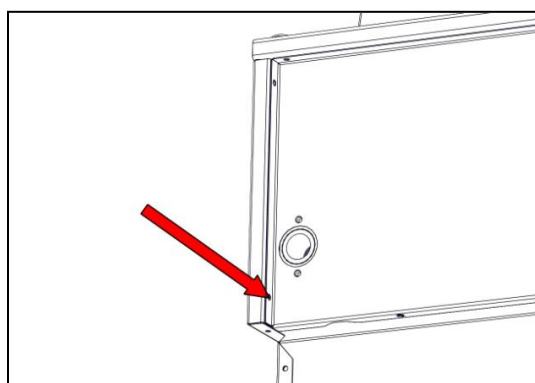

The unit is equipped with a 3-core flexible cord with standard 3 pin plug fitted with a 13A fuse. A regular 13A socket outlet can be used.

If supply is provided through a distribution fuse box, it must be via a fuse with a maximum rating of 13A.

In the event of mains cable being replaced, any new cable should comply with 60245 IEC 57 designation. (H05 RN - F).

6.3.2 This appliance is also provided with a terminal for connection of an external equipotential conductor. This terminal is in effective electrical contact with all fixed exposed metal parts of the appliance, and shall allow the connection of conductor having a nominal cross-section area of up to 10mm². It is located at the rear of the unit and identified by the following label and must only be used for bonding purposes.

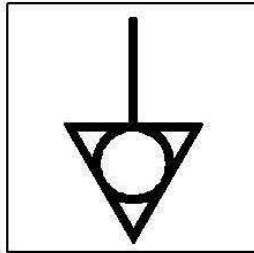

6.4 ASSEMBLY

6.4.1 Position appliance and level using feet or castor adjusters as shown below. Fit anti tilt device.

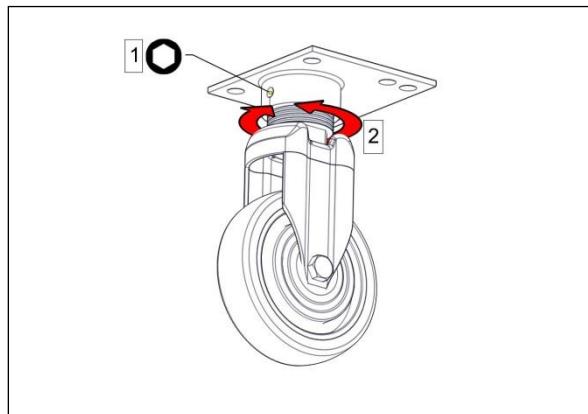
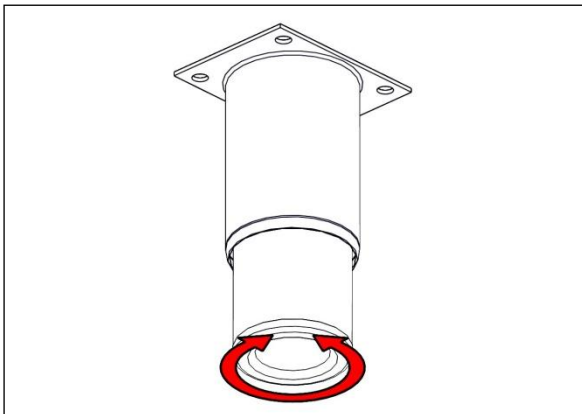

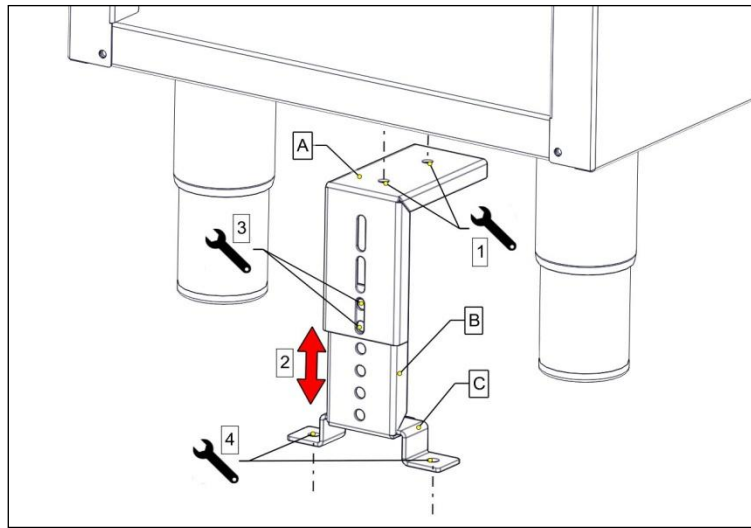

Appliances with castors should be fitted with accessories supplied according to separate instructions provided.

Connect appliance to gas supply and test for gas tightness as stated in 7.4.

6.5 COMMISSIONING

6.5.1 With gas supply still shut off, turn on electrical mains supply.

6.5.2 Open door and press temperature limit thermostat reset button (red) refer to section 2.6. Set burner switch to 'I' (on position)

6.5.3 Turn control knob to desired temperature (180°) and heat demand indicator will illuminate.

6.5.4 Fryer ignition sequence will commence and spark may be heard before unit locks out
 Note: Ignition system will attempt a second sequence, 14 seconds after completion of first try if no flame is detected during first attempt. (*Unit will only lock out after 2nd attempt*).

6.5.5 Neon next to burner switch inside door will illuminate to indicate lockout has occurred and that no burner flame is present. G9341 / G9341F.

6.5.6 Turn gas supply on.

6.5.7 Press lockout reset switch. (Lock out neon will extinguish).

6.5.8 Burner will ignite and heat indicator will illuminate to signify that burner is on.

If lockout should occur, repeat Steps 8 -9 until air is bled from supply and burner lights.

6.5.9 When burner flame is established, check for gas leaks. Care should be taken because MAINS VOLTAGE is present. Isolate after gas checks.

TEMPERATURE LIMIT THERMOSTAT

The unit is equipped with an additional temperature limit thermostat, independent of main controller.

In the case of operating thermostat failure, allowing oil temperature to rise above predetermined legislation safe zone (230°C), a limit device will activate and cut power to controller. It will also stop the flow of gas to burner, refer to **2.2**.

- a) Turn burner and temperature controls ON/OFF knob to OFF position.
- b) Allow oil to cool below 180°C
- c) Reset red button on limit thermostat with a pen or similar item, refer to **2.2.9**.
- d) Turn burner and temperature controls ON/OFF knob to ON position.
- e) Re-select temperature.
- f) If limit thermostat reactivates carry out fault finding on temperature control circuitry.



PLEASE FILL OUT THE INFORMATION TABLE ON THE FRONT COVER AFTER COMMISSIONING.

7 CONVERSION



BEFORE INSPECTION, SERVICING OR CONVERSION, TURN OFF GAS AND ELECTRIC AT ISOLATORS.

7.1 GAS CONVERSION CHECK LIST

- Change injectors in burner(s) and pilots
- Change gas type label.
- G30, 29mb at the burner or adjust SIT onboard governor if supply pressure is higher than 29mb.
- G31 the pressure is 34.5mb at burner. (Adjust SIT onboard governor clockwise to Maximum adjustment

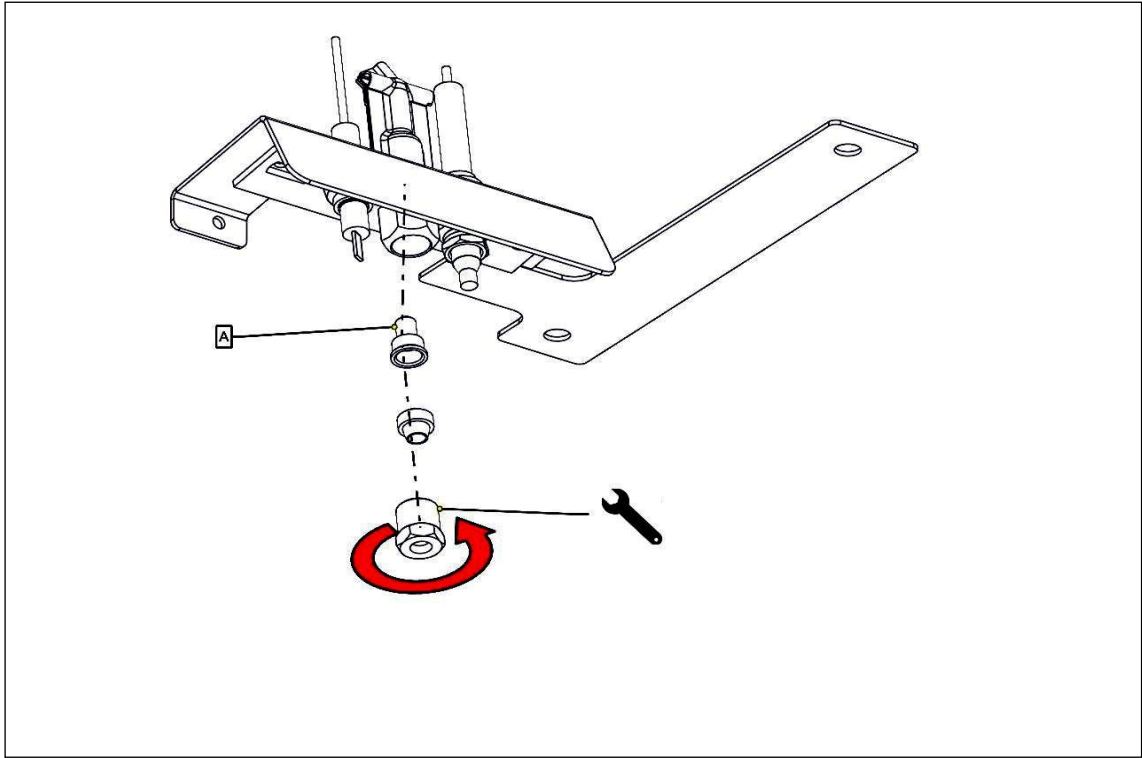

A – PILOT INJECTOR

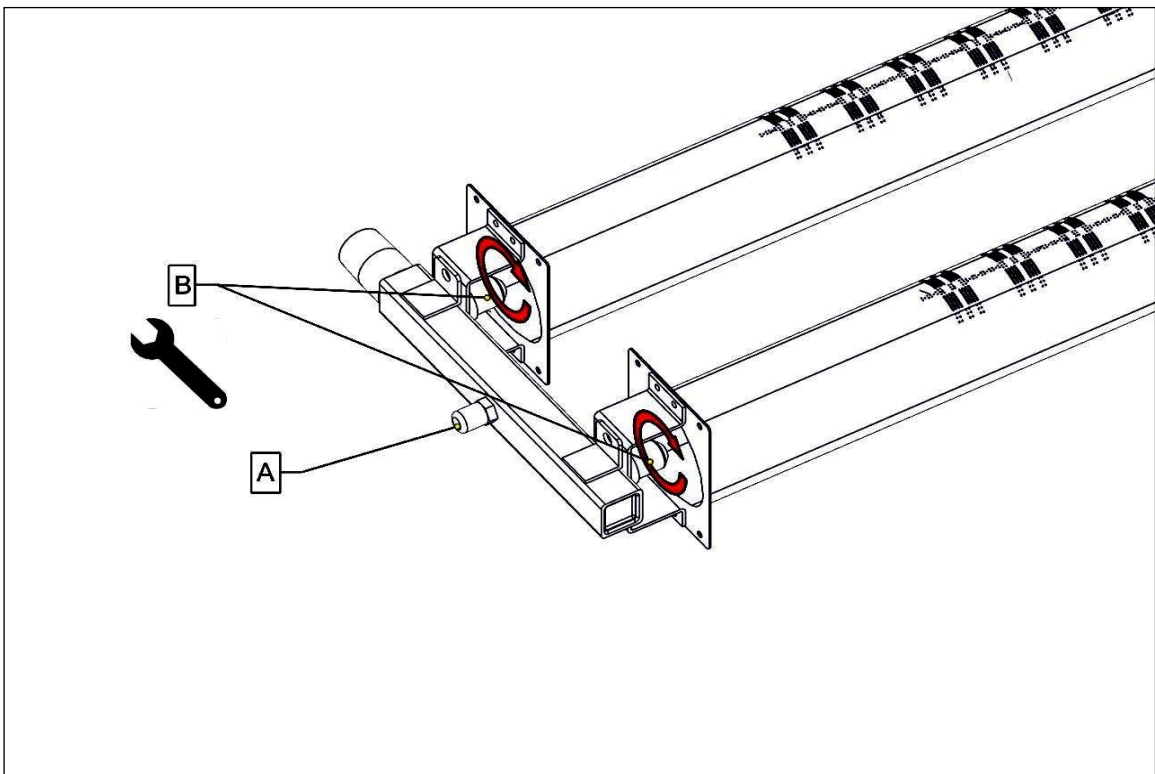

A – PRESSURE TEST NIBBLE

B – INJECTORS

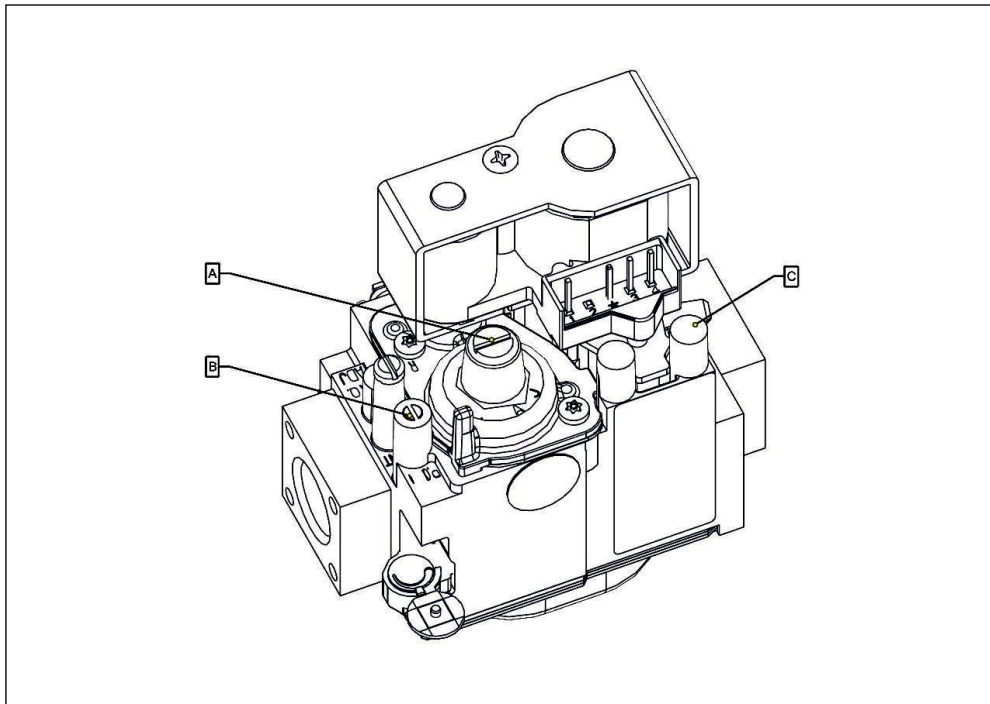

A- PRESSURE ADJUSTMENT SCREW

B- OUTLET PRESSURE

C- INLET PRESSURE

8 SERVICING

Turn off Electrical Power & Gas before Servicing

8.1 DOOR

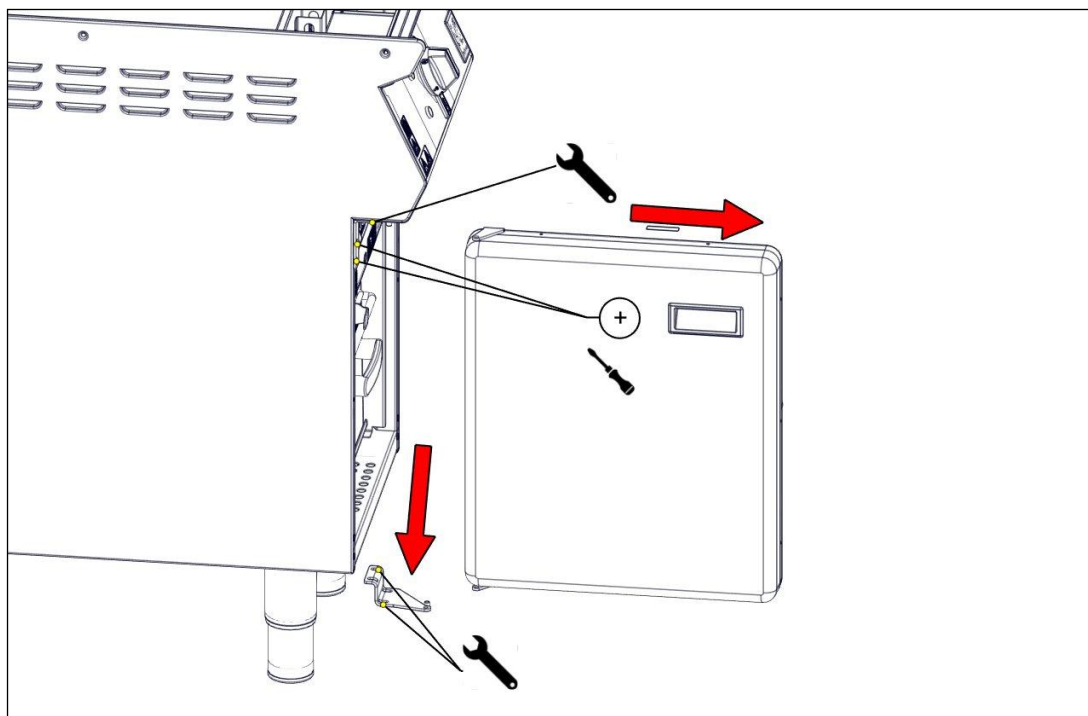

8.2 CONTROL PANEL

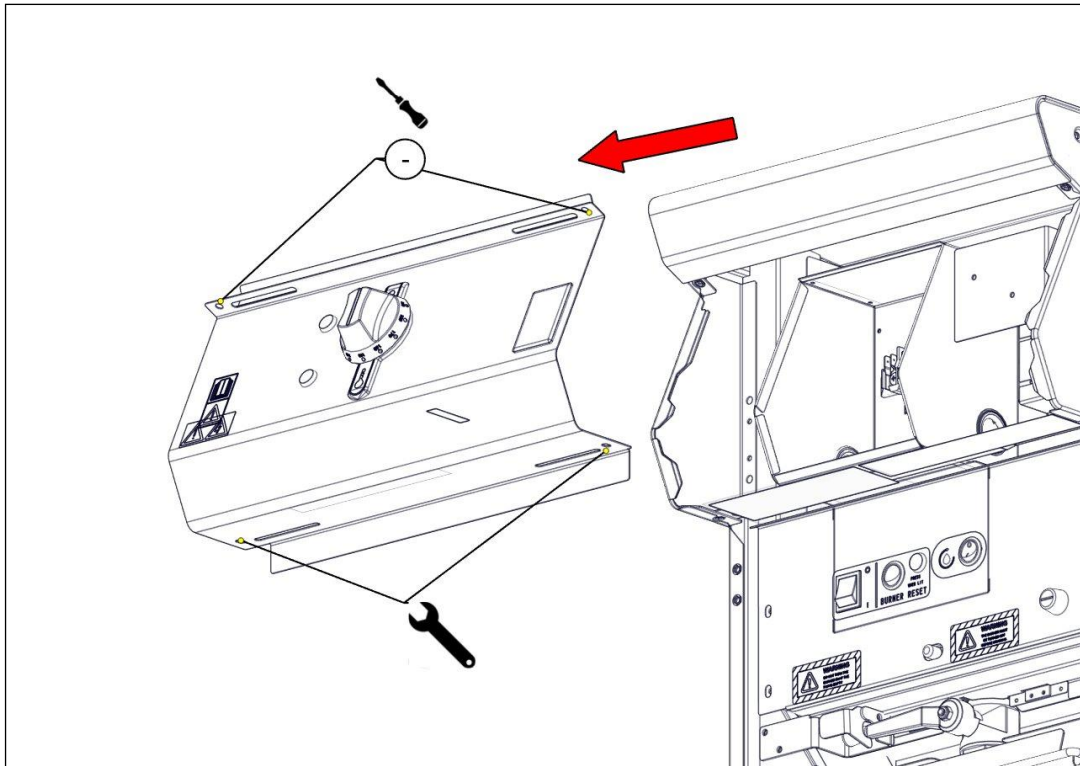

8.3 FASTRON CONTROLLER & NEONS

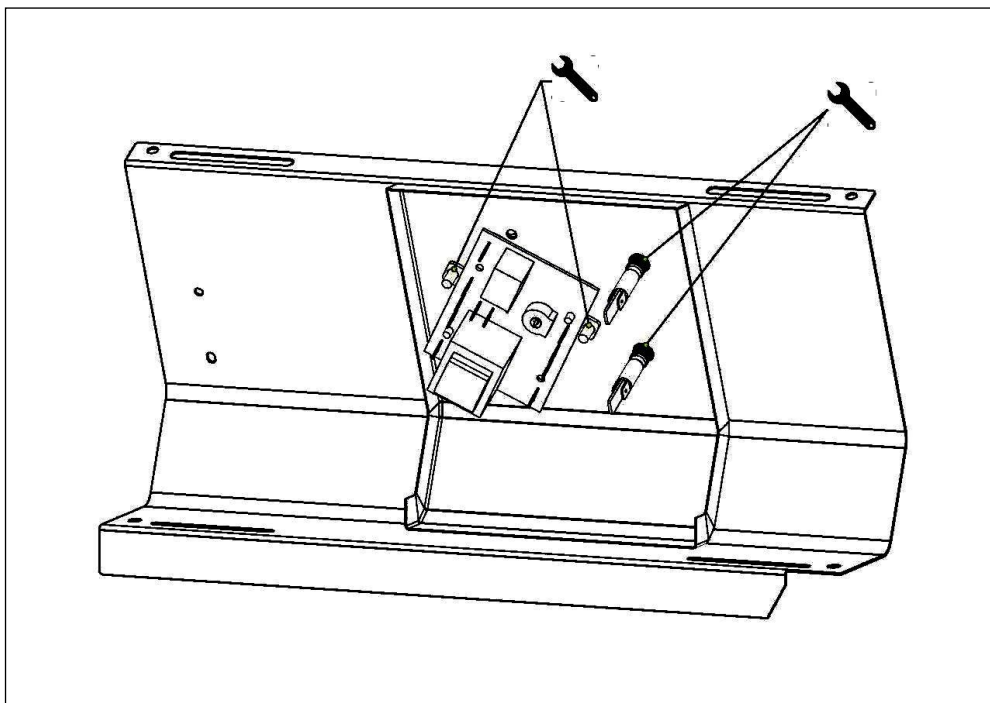

8.4 SWITCH PANEL

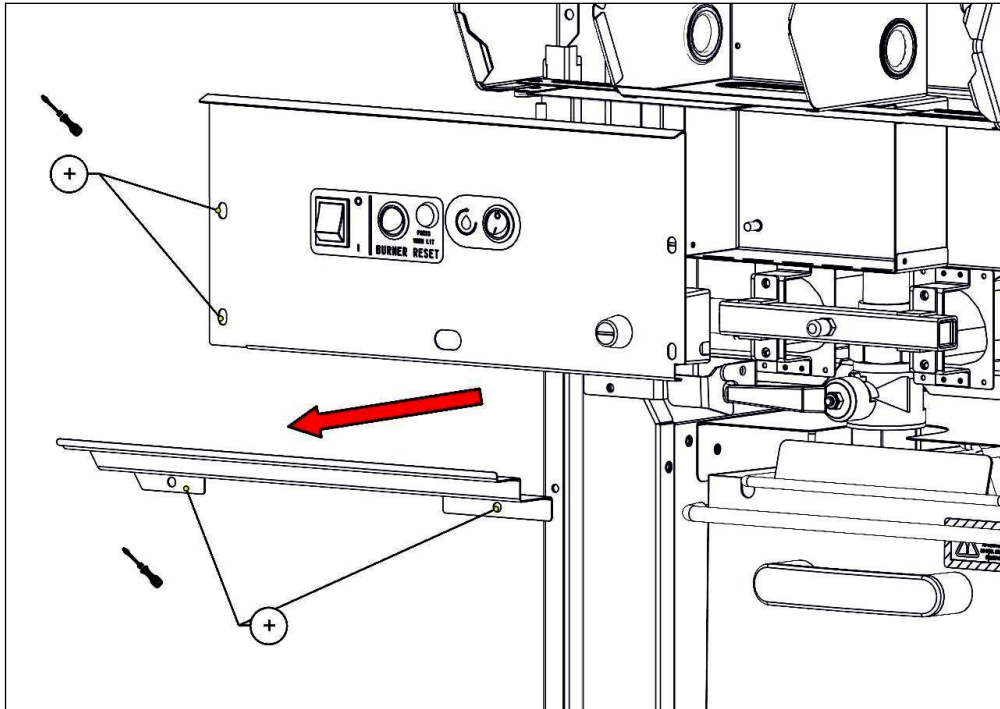

8.5 SWITCH & NEON REMOVAL

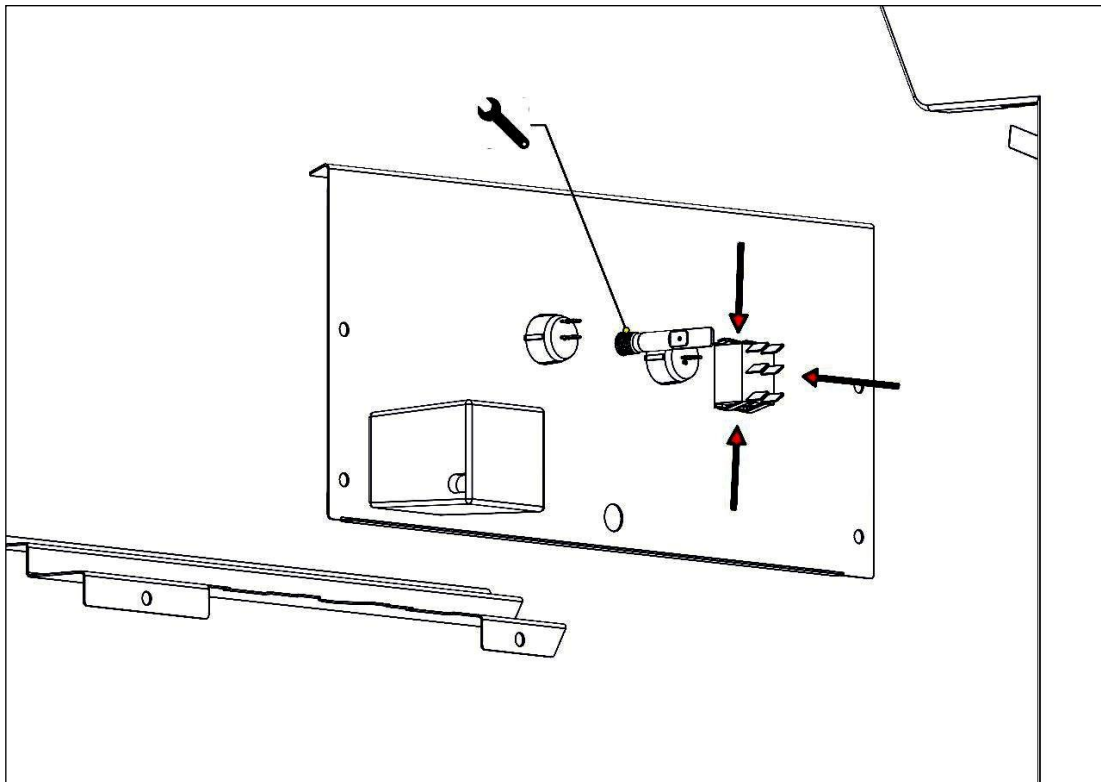

8.6 ACCESS TO SPARK BOX

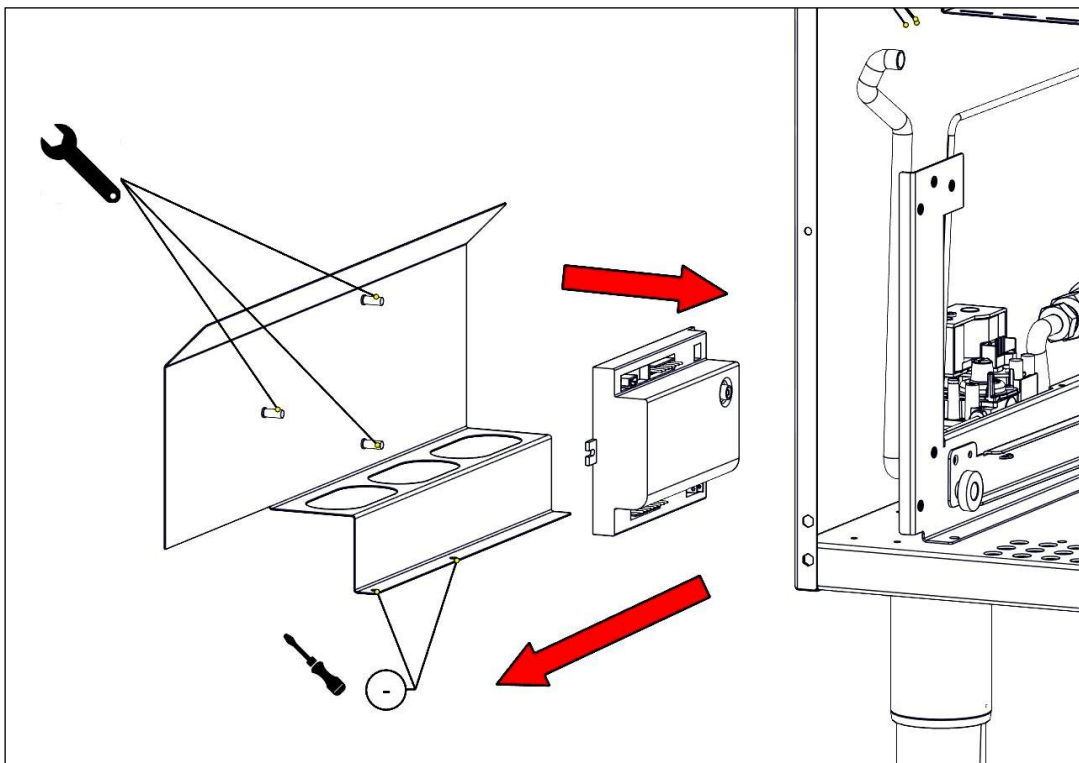
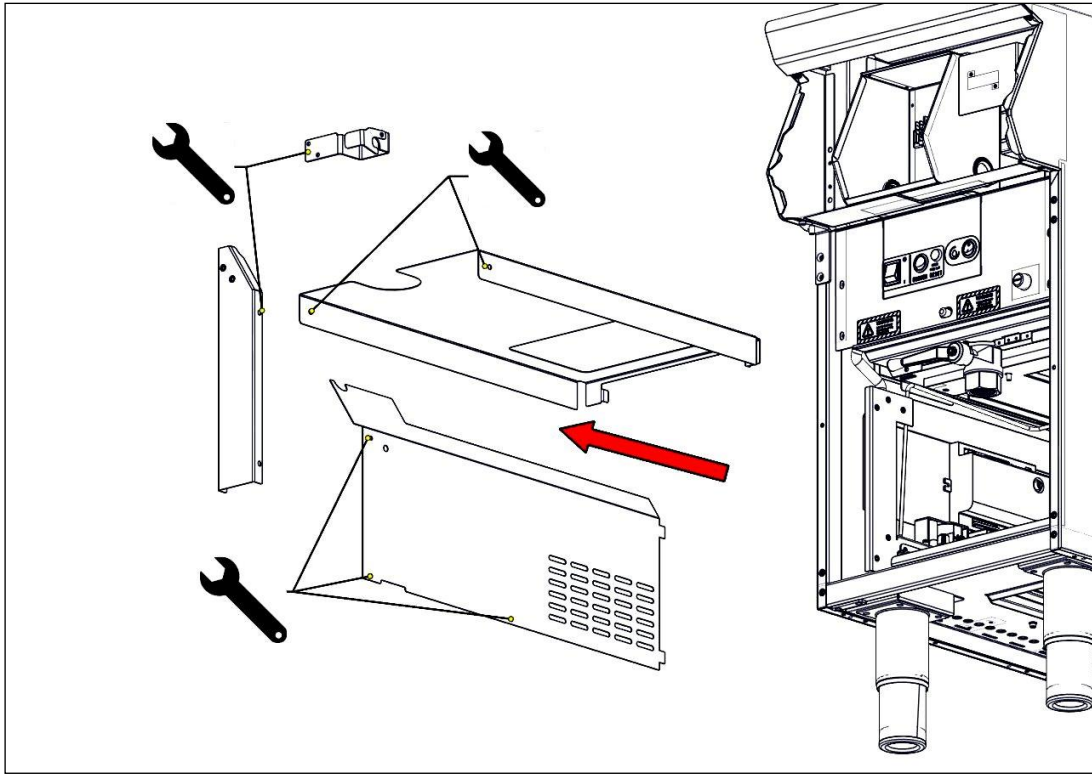

8.7 SIT GAS REGULATOR ACCESS

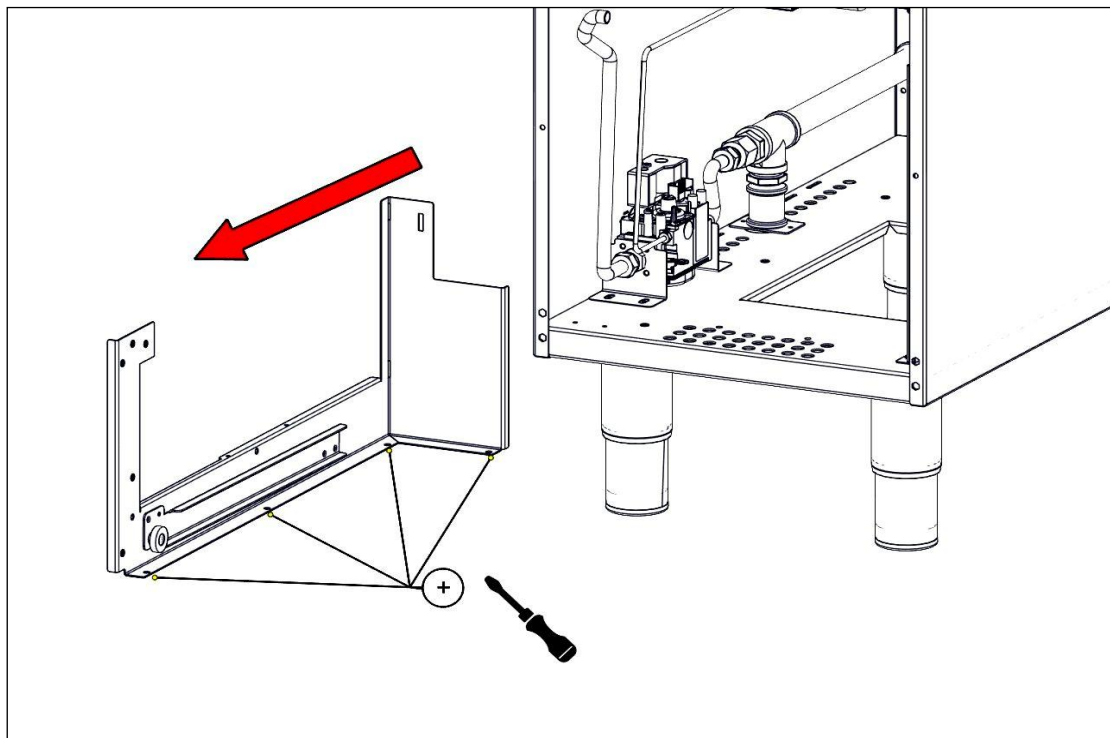

8.8 PUMP & TIMER REMOVAL

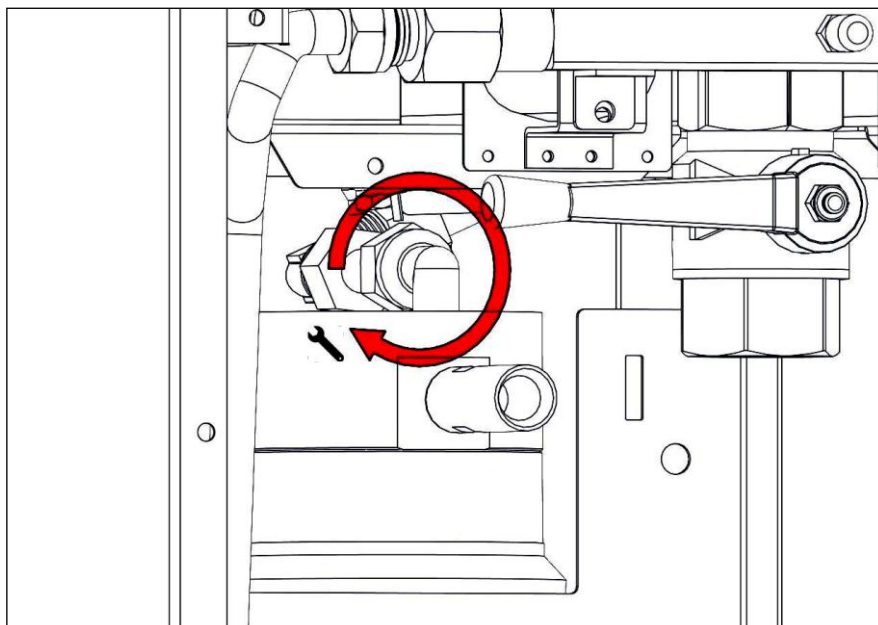

8.9

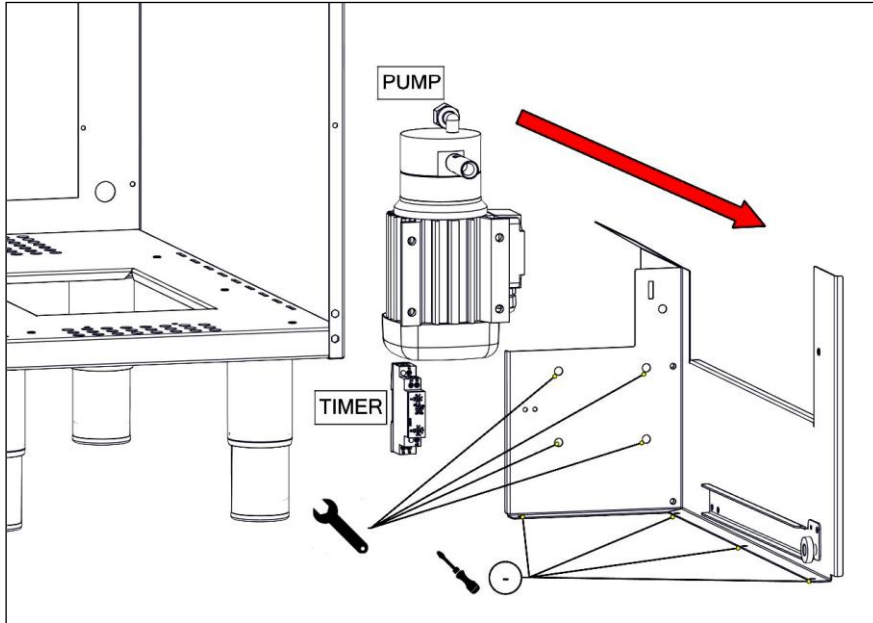

8.10 Timer Pump Settings for 230 volts

The settings are top function set to 0.8

Middle function to 10 minutes

Base function set to Wu



GOVERNOR SUPPLIED IS PART OF THE SIT GAS VALVE

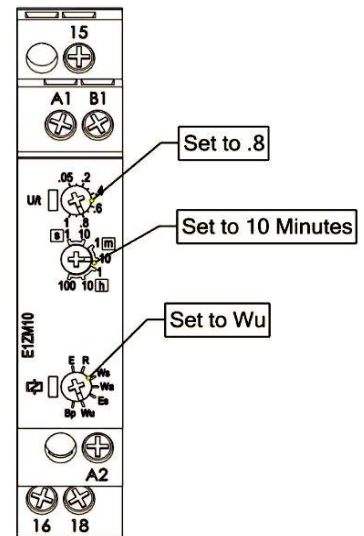

9 ACCESSORIES

- 9.1 Splash guard. Remove basket hanging panel, position splash guard and refit basket hanging panel.

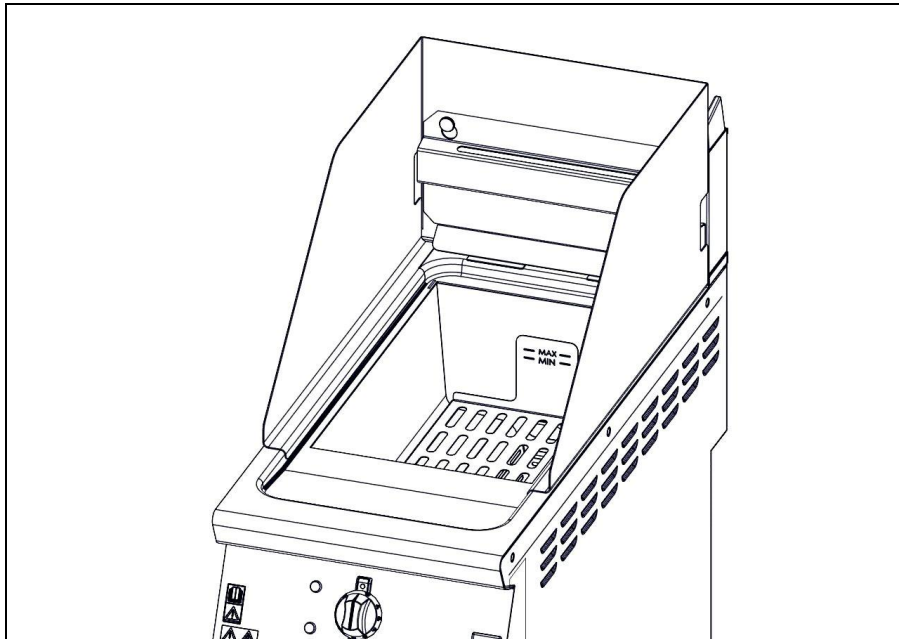

- 9.2 Drain hose. Push quick release connection (1), remove part (2) and fit to hose then fit hose to unit (1).

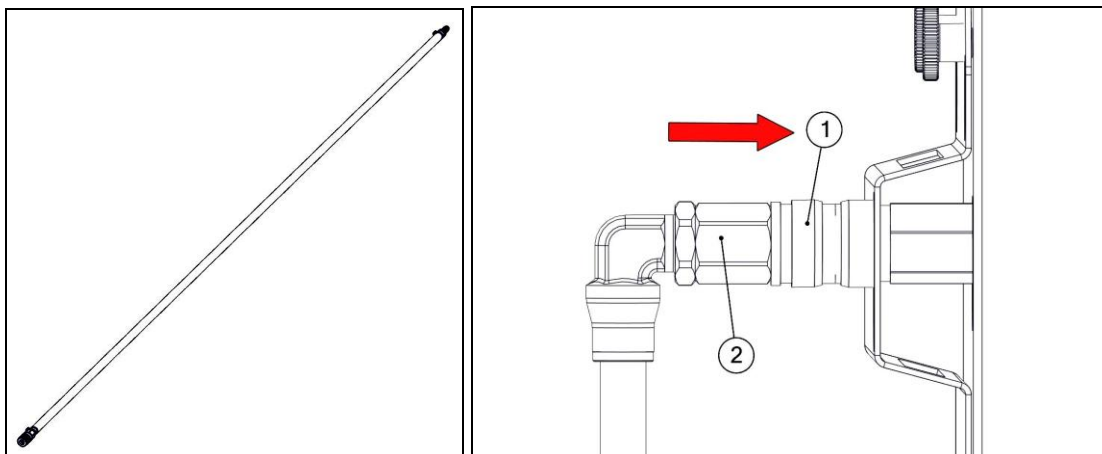

10 FAULT FINDING

FAULT	POSSIBLE CAUSES	REMEDY
Unit will not turn ON	No power to unit	Check mains power is connected and turned on
Unit will not light	No gas to unit	Turn gas on
Safety cut out Neon is on	No gas has reached pilot	Press reset button for further lighting attempts
Safety cut out activated	Overheating	Allow to cool below 180°C
Safety cut out activated	Low oil level	Add oil to min level mark
Pump will not run	Only runs when burner switch is in off (0) position	Turn off (0) burner switch
Pump stops running	Pump has ran cycle	Allow the pump to cool and then run once more
Pump stops running	Blocked pump	Clean Filters Regularly

Problem	Possible Cause	Possible Solution
Surge Boiling	Over loading with wet food	Reduce the amount of wet food
	Overloading with oil	Reduce the amount of oil to the Min Level
Pan Not Draining	Blocked with debris	Clean drain hole
Oil not Filtering	Blocked filters with debris	Clean filters inside the oil bucket
Debris in crumb tray in fry pot	Fryer use	Clean crumb tray
Debris in being returned to pan after filtering	Blocked filters in fryer bucket and overflowing, allowing unfiltered oil back to pan	Ensure oil has time to filter through strainer. Heavily unfiltered oil can block pump

11 SPARE PARTS

PART NAME
FASTRON CONTROLER
NEON RED
NEON AMBER
PLIOT INJECTOR
BURNER INJECTOR
OPERATING THERMOCOUPLE
SAFETY THERMOCOUPLE
ON/OFF SWITCH
RESET SWITCH
PUMP SWITCH
PUMP
TIMER
PILOT ASSEMBLY

When ordering spare parts please quote the following;

Model Number

Serial number

Gas Type

This information will be found on data plate attached to the appliance

Visit our website for further spares information.

12 SERVICE INFORMATION

It is recommended to have a maintenance contract with a local service provider.

SERVICELINE CONTACT:

(UK only)

Phone: +441438 363 000

Warranty Policy Shortlist

For our warranty policy please go to www.falconfoodservice.com

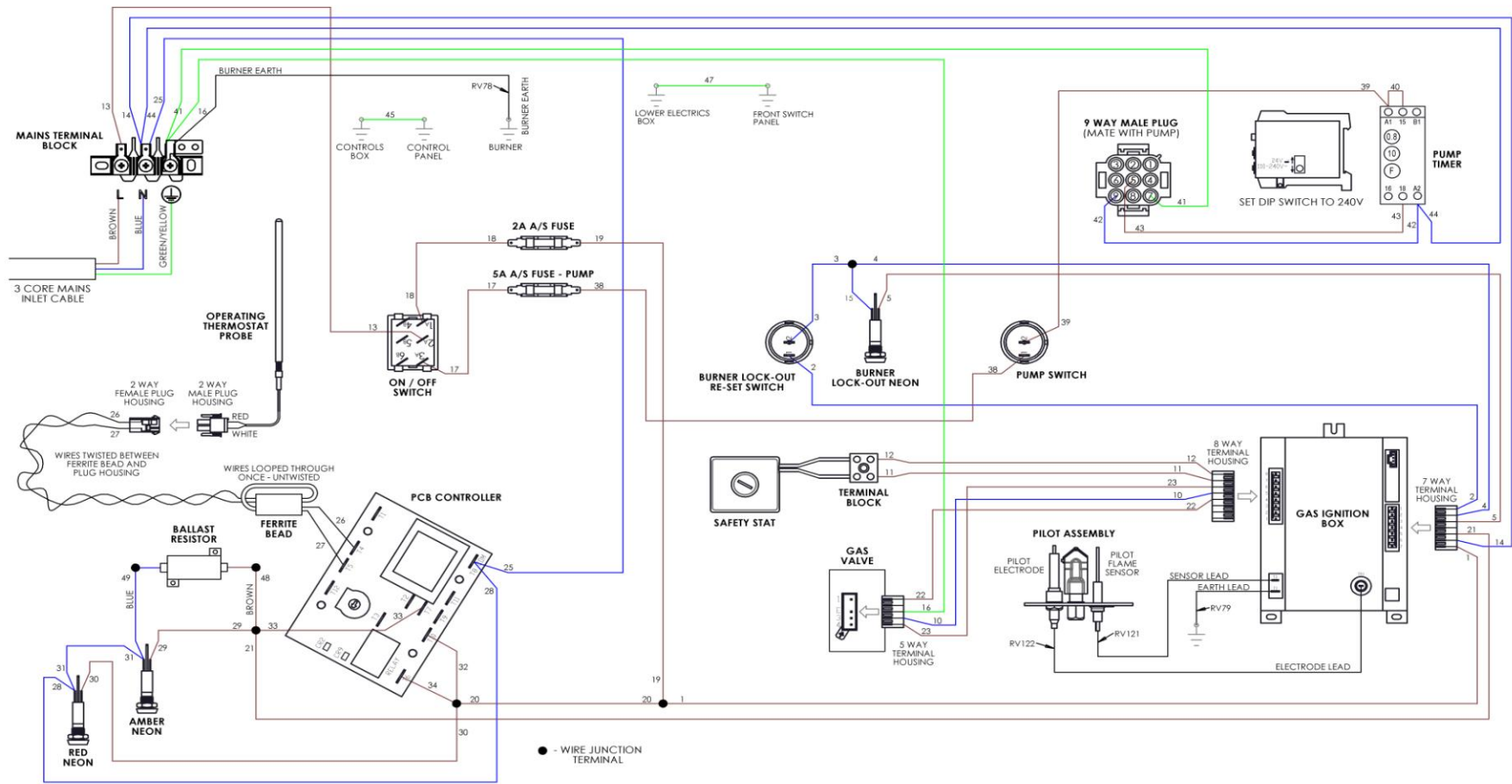

WIRE DIAGRAM FOR G9341F

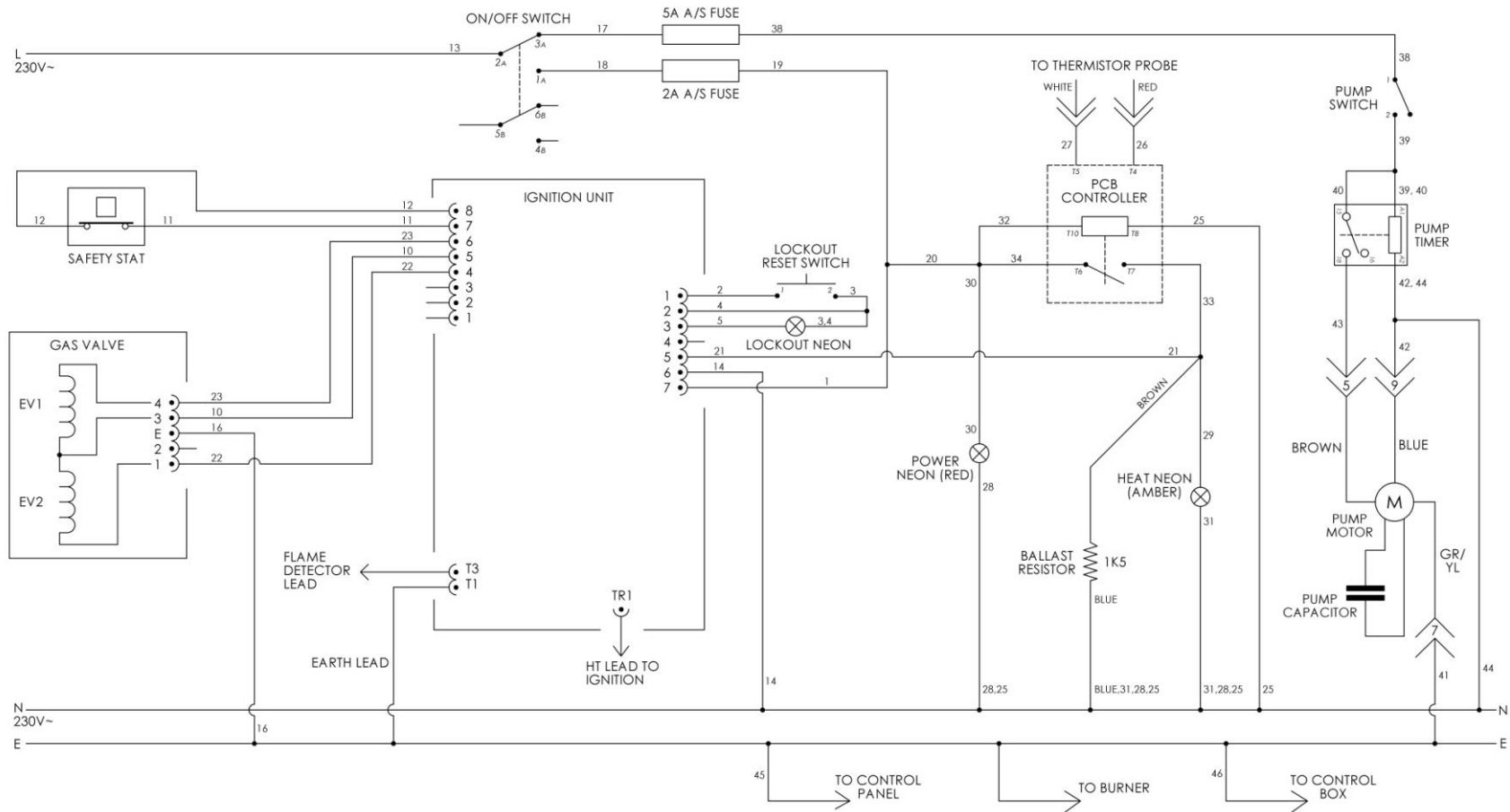

CIRCUIT DIAGRAM FOR G9341F

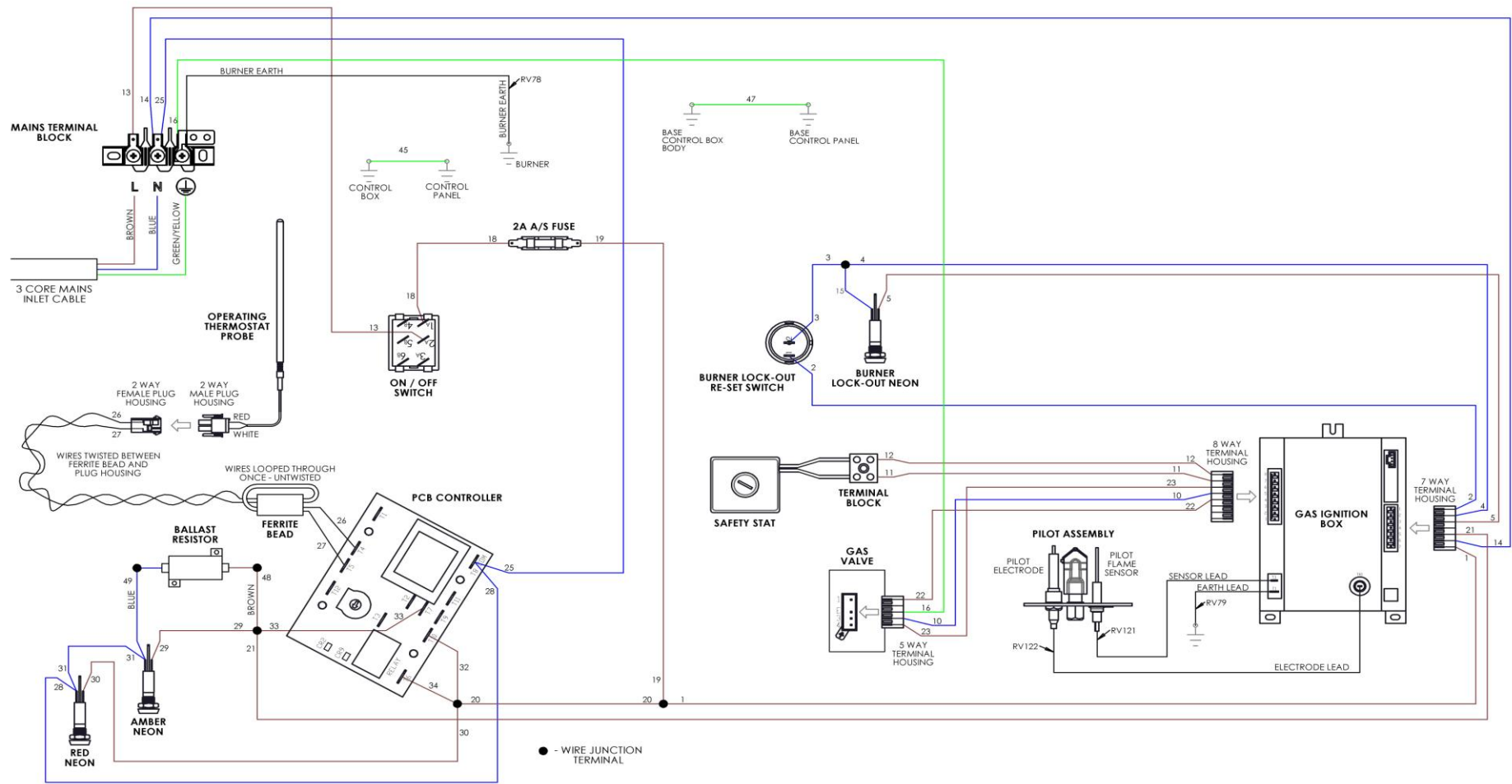

WIRE DIAGRAM FOR G9341

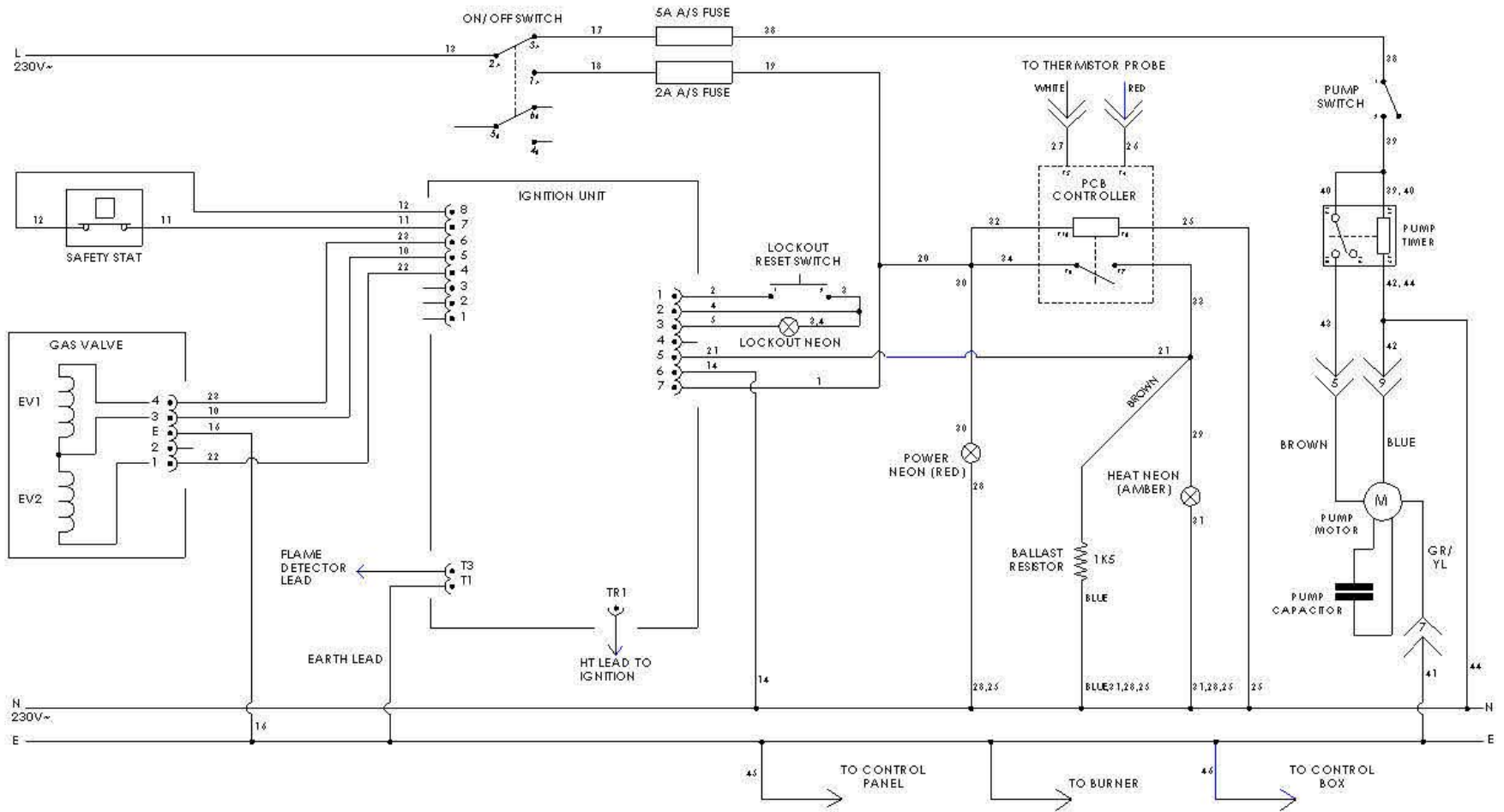

CIRCUIT DIAGRAM FOR G9341

