



**Model**

SM5 & SM7

**Product Description**

SM5 (Mixer, 5 litre, Light Duty)

SM7 (Mixer, 7 litre, Light Duty)

**Product Code**

5M237 (SM5)

5M238 (SM7)

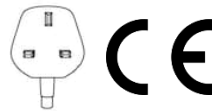

**Standard Features**

- Professional gear driven planetary mixer with a powerful, variable speed DC motor
- Comes complete with beater, whisk, dough hook and 5ltr /7ltr stainless steel removable bowl Ideally suited to smaller shops, delis, cafes, restaurants and small school kitchens
- Fully interlocked for safety whilst in use
- Ideal for preparation of light dough, pastry, cream, mayonnaise, sauces, crème patisserie, egg and mashed potato
- Head lifts for easy bowl and tool removal
- Constant mixing with step-less speed control
- Overload protection (NVR device)
- Plastic safety guard with ingredient chute

**Standard Accessories / Attachments**

- 1 x Whisk
- 1 x Beater
- 1 x Dough Hook
- 1 x 5 litre bowl (with SM5 only)
- 1 x 7 litre bowl (with SM7 only)

**Warranty**

Covered by Metcalfe 1-year warranty (parts and labour) and full after sales service

**Optional Accessories / Attachments**

	Item	Product Code
<b>SM5</b>	Spare Bowl	SM5/50401040F
	Beater	SM57/40201200F
	Whisk	SM57/40202400F
	Dough Hook	SM57/40201300F

	Item	Product Code
<b>SM7</b>	Spare Bowl	SM7/50401038F
	Beater	SM57/40201200F
	Whisk	SM57/40202400F
	Dough Hook	SM57/40201300F

## Drawings

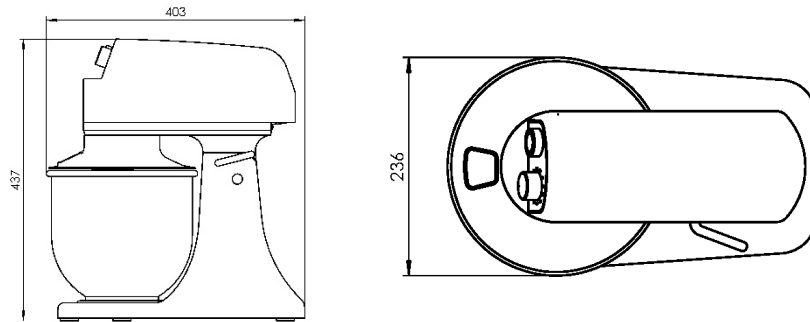

SM5 & SM7

## Specifications

Model	Capacity (ltr)	Speed of Shaft (r/min)	Motor (Volt)	Frequency (Hz)	AMP (A)	Power (watt)
SM5	5	100 – 938	230	50	2.1	350
SM7	7	100 - 938	230	50	2.1	350

## Capacity

Model	Sponge Mix (Kgs)	Liquid / Flour Mix (Kgs)	Eggs	Croissant (Kgs)	Brioche (Kgs)	Pizza (Kgs)	Mash (Kgs)
SM5	0.9	1.0	12	1	1	0.5	1.3
SM7	1.1	1.3	14	1.3	1.3	0.7	1.5

## Dimensions | Shipping Information

Model	Overall Dimensions (D x W x H)	Net Weight (Kg)	Packed Dimensions (D x W x H)	Packed Weight (Kg)
SM5	403 x 236 x 438	13,5	465 x 320 x 500	15,0
SM7	403 x 236 x 438	15,0	465 x 320 x 500	17,0

We reserve the right to alter the specification and technical details for this item at anytime without prior notice.

©Metcalfe Catering Equipment Ltd

Rev: 1.0 08/2018 - MJ

<p>Metcalfe Catering Equipment Ltd          Haygarth Park          Blaenau Ffestiniog          Gwynedd          LL41 3PF          Tel: 01766 830 456   Fax: 01766 831 170          E-mail: sales@metcalfecatering.com</p>		<p>View our current catalogue visit:  <a href="http://www.metcalfecatering.com/brochure">www.metcalfecatering.com/brochure</a>          Or scan the QR code</p> 
---	--	---