



POTATO PEELER PP-12+ / PPC-12+

Output: 12 Kg. per cycle. Aluminium made potato peeler.



FEATURES AND BENEFITS

Aluminium body potato peeler. Abrasive peeling. The abrasive is highly resistant and long lasting.

- ✓ Base Plate and chamber walls lined with abrasive.
- ✓ Aluminium body.
- ✓ PPC: Equipped with attachment drive to power accessories.
- ✓ Directable cylinder.
- ✓ Integral control panel complete with on/off push buttons and a 0-6 minute timer.

SALES DESCRIPTION

PPC: Equipped with attachment drive to power accessories.

INCLUDES

- ✓ Attachment drive to power accessories (PPC model).

ACCESSORIES

- Vegetable preparation attachment CR-143
- Meat mincer attachment HM-71
- Potato masher attachment P-132
- Stands for potato peelers
- Filters for potato peelers



www.sammic.co.uk
 Food Service Equipment Manufacturer
 Unit 2, Trevanah Road
 Troon Industrial Park
 LE4 9LS - Leicester
 uksales@sammic.com
 Tel.: +44 0116 246 1900



Project	Date
Item	Qty
Approved	

DYNAMIC PREPARATION
COMMERCIAL POTATO PEELERS

product sheet
updated 22/03/2019



POTATO PEELER PP-12+ / PPC-12+

Output: 12 Kg. per cycle. Aluminium made potato peeler.



SPECIFICATIONS

Hourly production: 220 Kg / 270 Kg

Capacity per load: 12 Kg

Timer (min-max): 0' - 6'

Plate speed: 317 rpm

External dimensions (WxDxH)

✓ Width: 395 mm

✓ Depth: 700 mm

✓ Height: 503 mm

External dimensions with stand

✓ Width with stand: 411 mm

✓ Depth with stand: 700 mm

✓ Height with stand: 1015 mm

Net weight: 38 Kg

Noise level (1m.): 70 dB(A)

Background noise: 32 dB(A)

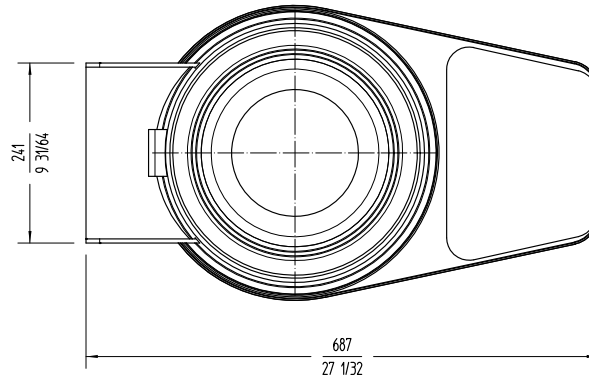
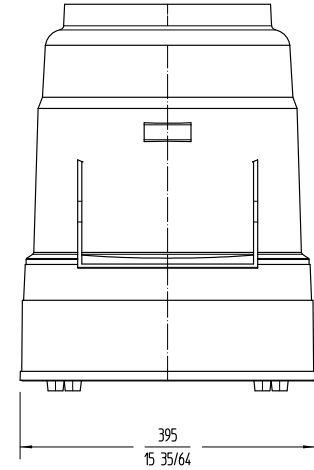
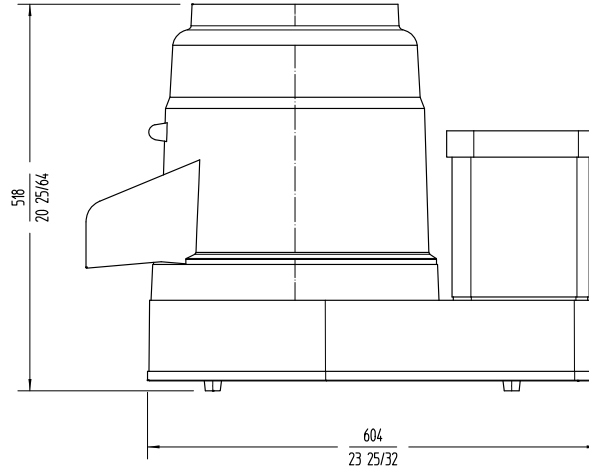

DYNAMIC PREPARATION
COMMERCIAL POTATO PEELERS

AVAILABLE MODELS

1000420 Potato peeler PP-12+ 230-400/50/3 ·370W

1000421 Potato peeler PP-12+ 230/50/1 ·400W

1000440 Potato peeler PPC-12+ 230-400/50/3 ·550W

1000441 Potato peeler PPC-12+ 230/50/1 ·550W

* Ask for special versions availability



www.sammic.co.uk

Food Service Equipment Manufacturer

Unit 2, Trevanah Road

Troon Industrial Park

LE4 9LS - Leicester

uksales@sammic.com

Tel.: +44 0116 246 1900



Project

Date

Item

Qty

Approved

product sheet
updated 22/03/2019