



P0425-2 - Lincat Electric Counter-top Pizza Oven - Twin-Deck - W 886 mm - 6.0 kW

Transport yourself to the Centro Storico district of Naples with the authentic taste of the pizzas from the Lincat Twin-Deck Electric Pizza Oven.

- ✓ Ideal for restaurants, pizzerias, takeaways, fast food outlets, canteens and leisure establishments
- ✓ Perfect for deep pan, thin crust, fresh dough, part baked or frozen pizzas, as well as a variety of other foods such as ciabatta, naan, garlic bread, lasagna, jacket potatoes, pies, pasties and pastries
- ✓ Firebrick base for crisp, even cooking of pizza bases and a maximum temperature of 480°C
- ✓ Internal illumination for better visibility of product and enhanced appearance in front of house applications
- ✓ Independent controls for each deck. Independently controlled top and base of oven compartment for each deck
- ✓ Thermostatic control and temperature display gauge to monitor oven temperature more accurately
- ✓ Double-glazed door construction for energy efficiency with toughened glass for safety
- ✓ 20 minute audible timer

Specifications

Summary

Brand	Lincat
Range	Specialist
Power Type	Electric
Unit Type	Counter-top
Available in UK Only	No
UK Warranty	2 Years Parts and Labour Warranty
Export Warranty	Contact your local dealer
GTIN	5056105103684

Power and Performance

Total Power kW	6.0
Temperature Range °C	80-480
IP Rating	IP23
Temperature Control	Mechanical
Oven Rating kW	6.0

Key Specifications

Number of Decks	2
------------------------	---

Capacity

Pizza Capacity	96 x 10" [25cm] thin crust pizzas [chilled]
-----------------------	---

Weights and Dimensions

Unit Height (External) mm	665
Unit Width (External) mm	886
Unit Depth (External) mm	825
Height (Internal) mm	2 x 160
Width (Internal) mm	2 x 550
Depth (Internal) mm	2 x 535
Net Weight Kg	109.9

Supply Connections

Requires Installation	Yes
Requires Electrical Supply	Yes
UK 3 Pin Plug	No
Requires Hardwiring	Yes
Electrical Supply Rating Watts	6,000
Single Phase Amps	26.0
Single Phase Voltage	230
Three Phase Amps	L1=8.7; L2=8.7; L3=8.7
Three Phase Voltage	400

Shipping

Packed Weight Kg	114
Packed Height cm	96
Packed Width cm	100
Packed Depth cm	97

Available Accessories

PO425/FS

PO425 FLOORSTAND

Technical Picture

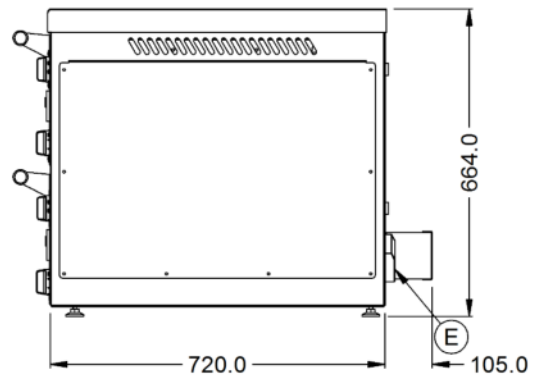
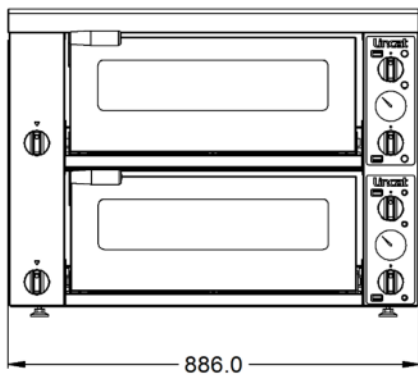
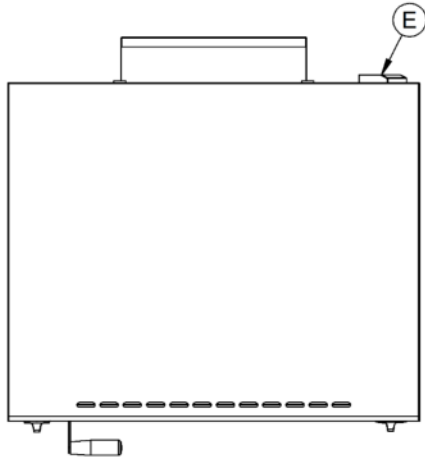

Lincat Limited

Whisby Road,
Lincoln, LN6 3QZ,
United Kingdom

Company No: 2175448

A member company of



Customer Care

Tel: +44 1522 875500
Email: care@lincat.co.uk

Export Customers

Tel: +44 1522 503250
Email: export@lincat.co.uk

Opening Hours

Monday – Friday:
8.30am – 5pm