

TEMPOMATIC 3 :

SPECIFICATIONS

Electronic, deck-mounted tap for washbasins with 6V Lithium battery, solenoid valve and electronic controls integrated in the body of the tap. Infra-red presence detection. Adjustable flow straightener with flow rate set at 3 lpm, with anti-blocking. Duty flush to prevent stagnant water in the system if not used for prolonged periods. Chrome-plated solid brass body and reinforced fixing by two rods and back-nuts, maintenance access cap is locked in place by hidden screws. Supplied with F3/8" PEX flexibles, stop cocks, non-return valve and filter. Brand DELABIE type TEMPOMATIC 3 with integral 6V battery. Ref. 442006 (or approved equivalent).

x Réf. : 442006 : battery, solenoid valve and electronic control unit integrated

- » • 6V Lithium battery type 223 supplied.
- Automatic duty flush for ~45 seconds every 24 hours after the last use reduces bacterial development.
- We recommend installing a thermostatic mixing valve to supply safe, temperature controlled mixed water.



FONCTIONING AND APPLICATION

- Operation: Opens/closes when hands are presented/removed from detection zone. Anti-bacterial duty flush (45 sec. flush every 24h after the last use).
- Use: Public places, healthcare sector and food industry, facilities for people with reduced mobility, offices, restaurants, etc.

PRODUCT ADVANTAGES

- **INSTALLATION:** Can be installed on any isolated point-of use for new builds as well as renovation; there is no need for electrical connections (thanks to the batteries).
- **SENSOR** hidden at the end of the spout optimises detection of hands in any position.
- **CONSTANT FLOW RATE:** flow straightener set at 3 lpm at 3 bar (flow rate can be adjusted if the Pressure is < 3 bar) (DELABIE patented).

- **WATER SAVING:** almost 90% compared to conventional mixers/taps (shorter and lower flow rate).
- **TOTAL HYGIENE:** - no manual contact prevents the spread of germs carried by the hands. Duty flush means no water stagnation, reducing bacterial development. • **EASY TO MAINTAIN:** independent elements can be accessed via the maintenance cap. LED diagnostic aids. Average battery life is 3-6 years, sensor flashes when batteries are spent.
- **ANTI-BLOCKING:** prevents continuous flow (automatic shut-off after 30 seconds of continuous detection, prevents continuous flow, resets automatically).
- **RELIABLE:** solenoid valve will not corrode. Reliable presence detection.
- **HYGIENIC FLOW STRAIGHTENER:** scale build-up is 5-times slower than on a conventional aerator.
- **3 YEAR WARRANTY.**

442006

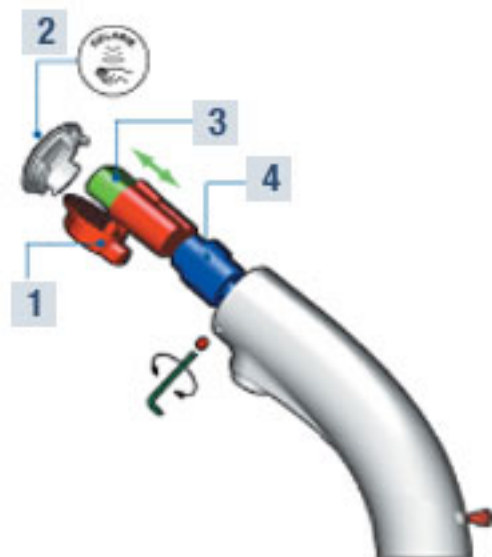
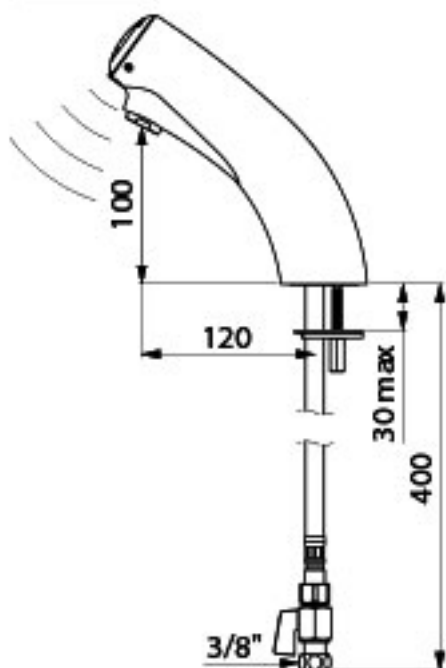

- 1** **Electronique en capsule étanche**
- 2** **Capot verrouillé par 2 vis cachées**
- 3** **Piles Lithium 6V :**
changement rapide des piles sans couper l'eau ni déposer le robinet.
- 4** **Cartouche électrovanne :**
nettoyage ou remplacement de l'électrovanne sans dépose du robinet.



Fixation renforcée
par 2 tiges inox et
contre-écrous